

Roll No.

Total Pages : 4

301401

October, 2020

B.Tech. (CE/IT/CSE) - IV SEMESTER

Discrete Mathematics (PCC-CS-401)

Time : 3 Hours]

[Max. Marks : 75

Instructions :

- 1. It is compulsory to answer all the questions (1.5 marks each) of Part-A in short.*
- 2. Answer any four questions from Part-B in detail out of 7 questions.*
- 3. Different sub-parts of a question are to be attempted adjacent to each other.*

PART - A

- (a) State and Prove Demorgan's Law. (1.5)

(b) What are quantifiers? Give Example. (1.5)

(c) Define multisets and various operations on them. (1.5)

(d) Define Cut point and Bridge in Graphs. (1.5)

(e) Define Circular permutation. (1.5)

(f) Let $A = \{1, 2, 3, 4, 6, 7, 8, 9\}$ and let R be the relation on $A \times A$ defined as $(a, b) R (c, d)$ if $a + d = b + c$. Prove that R is an equivalence relation. (1.5)

- (g) What is a Perfect Graph? Explain with example. (1.5)
- (h) Let f be a function from A to B , where $A = B = \text{Set of real numbers } \mathbb{R}$ and $f(a) = (2a-1)/3$. Find f^{-1} . (1.5)
- (i) In the different permutations of the word 'EXAMINATION' are listed as in a dictionary, How many items are there in the list before the first word starting with E. (1.5)
- (j) What are bijective functions? Explain with Example. (1.5)

PART - B

2. (a) Among 100 Students, 32 study Mathematics, 20 study physics, 45 study Biology, 15 study mathematics & Biology, 7 study Mathematics & Physics, 10 study Physics & Biology and 30 do not study any of the three subjects.
- (i) Find the number of students studying all three subjects.
- (ii) Find the number of students studying exactly one of the three subjects. (6)
- (b) Use mathematical induction to show that
- $$1 + 2 + 2^2 + \dots + 2^n = 2^{n+1} - 1$$
- for all nonnegative integers n . (5)
- (c) Define Cantor's Diagonal Argument (4)

3. (a) Find whether the following implication is tautology, contradiction or contingency :

(i) $(p \Rightarrow q) \vee r \Leftrightarrow [(p \vee r) \Rightarrow (q \vee r)]$

(ii) $(p \wedge q \Rightarrow r) \Leftrightarrow (p \Rightarrow r) \vee (q \Rightarrow r)$ (10)

(b) Find the validity of the following Argument :

If I study then I will not fail in mathematics, If I donot play football then I will study, But I failed in Mathematics. Therefore I must have played football

(5)

4. Explain the following(with proper Example) :

(i) Bipartite Graph.

(ii) Euler Formula.

(iii) Partial Order Relation. (15)

5. (a) Construct the binary tree for following traversals of a tree :

Preorder : a b d e h c f g i j

Inorder : d b h e a f c i j g (5)

(b) Explain and prove Schroeder Bernstein theorem. (10)

6. (a) Consider an algebraic system $(G, *)$, where G is the set of all non-zero real numbers and $*$ is a binary operation defined by

$$a * b = (ab)/4$$

Show that $(G, *)$ is an abelian group. (10)

(b) What is Field in algebraic systems? Explain with example. (5)

7. (a) Find the shortest distance between A and Z using Dijkstra algorithm stepwise: (10)

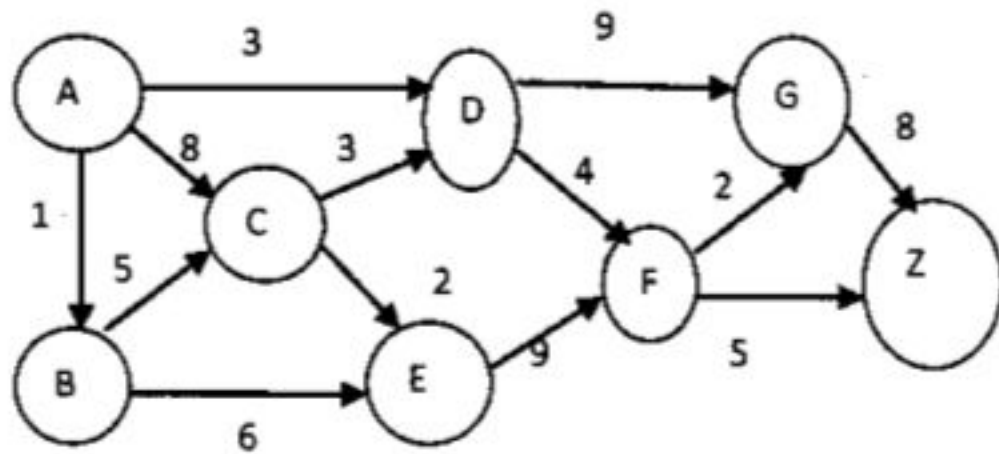

- (b) Draw the Minimum Spanning tree for following graph: (5)

